

# Mill Duty I-Beam Festoon Systems

Magnetek's Electromotive Systems Mill Duty I-Beam Festoon Systems efficiently and economically deliver power and control to cranes used in a variety of severe industrial environments.

## Features

- Standard 4" diameter trolley wheel
- Capacity of flanged main wheel trolley:
  - 800 lbs. @ 400 ft./min.
  - 600 lbs. @ 600 ft./min.
- Trolleys manufactured from low carbon steel and are zinc plated with gold dichromate finish
- Bar clamps are available to secure cable
- Capacity of non-flanged trolley wheel (with side guide wheels)
  - 1,000 lbs. @ 400 ft./min.
  - 800 lbs. @ 600 ft./min.
- Trolleys are available with galvanized finish
- Trolleys are available in stainless steel

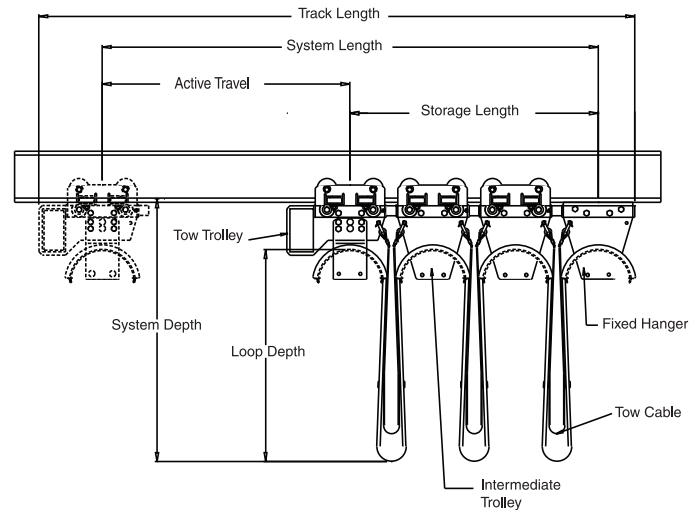

Trolleys are available for installation on 8" through 12" I-Beams. Whatever your requirements, Magnetek can provide the power and control you need in a Mill Duty I-Beam Festoon System.

<b>Track Length</b>	Total Length of festoon track or I-Beam
<b>System Length</b>	Total extended length of festoon system. Centerline of end cable clamp to centerline of tow trolley/tow bar.
<b>Storage Length</b>	Distance from centerline of tow trolley to centerline of end cable clamp when festooned equipment is parked in the starting position. Storage distance may become exceedingly long on longer festoon systems but can be shortened by increasing the loop depth of the cable.
<b>Active Travel</b>	Actual tow trolley travel distance of festooned equipment from the starting position to the final position along the track length.
<b>System Depth</b>	The distance from the running surface of the track or I-Beam to the lower most point of the cable loop.
<b>Loop Depth</b>	The distance from the trolley saddle surface to the lower most point of the cable loop.
<b>Tow Trolley</b>	Outer trolley that provides an area to interface with the tow bar that is mounted on the traveling portion of the festooned equipment.
<b>Intermediate Trolley</b>	Trolleys are located between the tow trolley and the end cable clamp providing cable support as system expands.
<b>Fixed Hanger/End Cable Clamp</b>	Secures cable at the beginning of the festoon system, reducing cable stress at the termination points.
<b>Tow Cable/Chain</b>	Cable or chain secured between each trolley to reduce cable stress along the festoon system. Primarily used in applications with heavy cable loads or high travel speeds.



**MAGNETEK**  
MATERIAL HANDLING

**ELECTROMOTIVE SYSTEMS**  
**TELEMOTIVE**  
**ENRANGE**  
**MONDEL**

# Mill Duty Fixed Cable Clamp

Fixed cable clamp provides strain relief at the stationary end of the festoon system. The fixed end clamp may be bolted or welded directly to the lower flange of the I-Beam.



Cable bar clamps are optional.

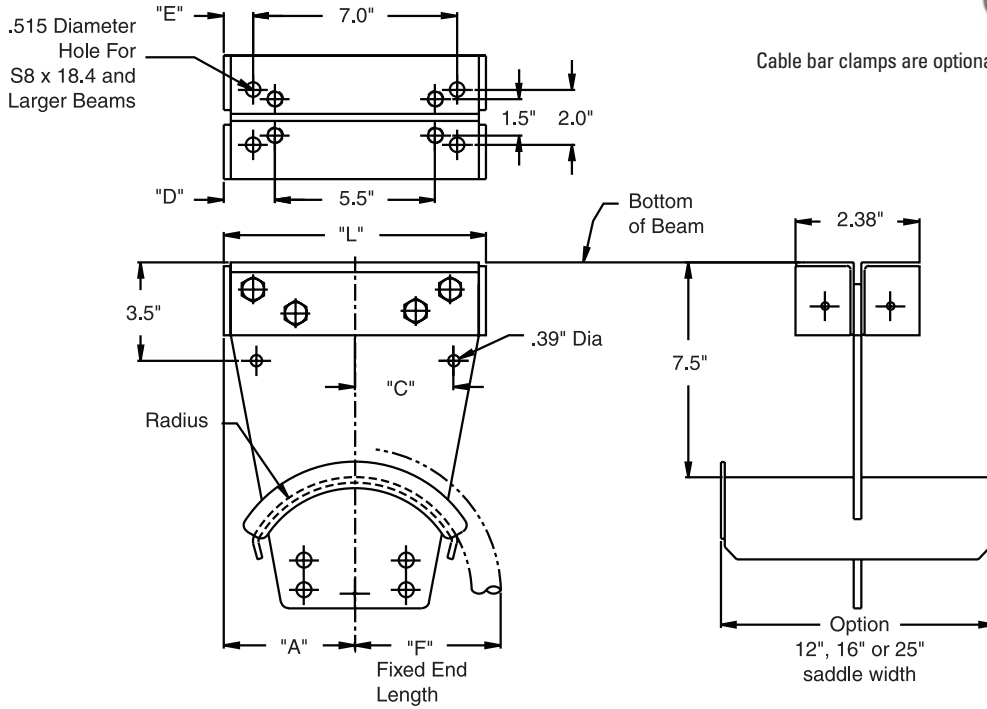

SADDLE															
Type	Radius	Dim "L"	Dim "F"	Dim "A"	Dim "E"	Dim "D"	Dim "C"	Type	Radius	Dim "L"	Dim "F"	Dim "A"	Dim "E"	Dim "D"	Dim "C"
A4	4"	9.00"	5.00"	4.50"	1.00"	1.75"	3.38"	E6	6"	15.50"	8.25"	7.75"	4.25"	5.00"	5.37"
B4	4"	9.00"	5.00"	4.50"	1.00"	1.75"	3.38"	F6	6"	15.50"	8.25"	7.75"	4.25"	5.00"	5.37"
C4	4"	9.00"	5.00"	4.50"	1.00"	1.75"	3.38"	A8	8"	18.50"	9.75"	9.25"	5.75"	6.50"	7.55"
D4	4"	11.00"	6.00"	5.50"	2.00"	2.75"	3.38"	B8	8"	18.50"	9.75"	9.25"	5.75"	6.50"	7.55"
E4	4"	11.00"	6.00"	5.50"	2.00"	2.75"	3.38"	C8	8"	18.50"	9.75"	9.25"	5.75"	6.50"	7.55"
F4	4"	11.00"	6.00"	5.50"	2.00"	2.75"	3.38"	D8	8"	20.50"	10.75"	10.25"	6.75"	7.50"	7.55"
A6	6"	13.50"	7.25"	6.75"	3.25"	4.00"	5.37"	E8	8"	20.50"	10.75"	10.25"	6.75"	7.50"	7.55"
B6	6"	13.50"	7.25"	6.75"	3.25"	4.00"	5.37"	F8	8"	20.50"	10.75"	10.25"	6.75"	7.50"	7.55"
C6	6"	13.50"	7.25"	6.75"	3.25"	4.00"	5.37"	A0	10"	23.50"	12.25"	11.75"	8.25"	9.00"	9.83"
D6	6"	15.50"	8.25"	7.75"	4.25"	5.00"	5.37"								

# Mill Duty Tow Cable Clamp

A less expensive alternative to a tow trolley, the tow cable clamp is designed to be mounted to the moving equipment directly in-line with the festoon system. The tow cable clamp is not recommended for equipment that may have vertical movement of 2.00 inches or more while traveling the overall length of the system.

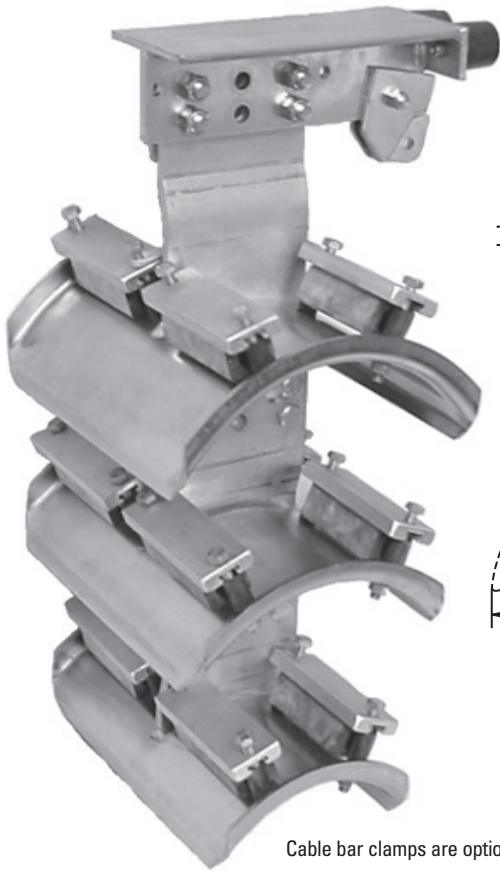

Cable bar clamps are optional.

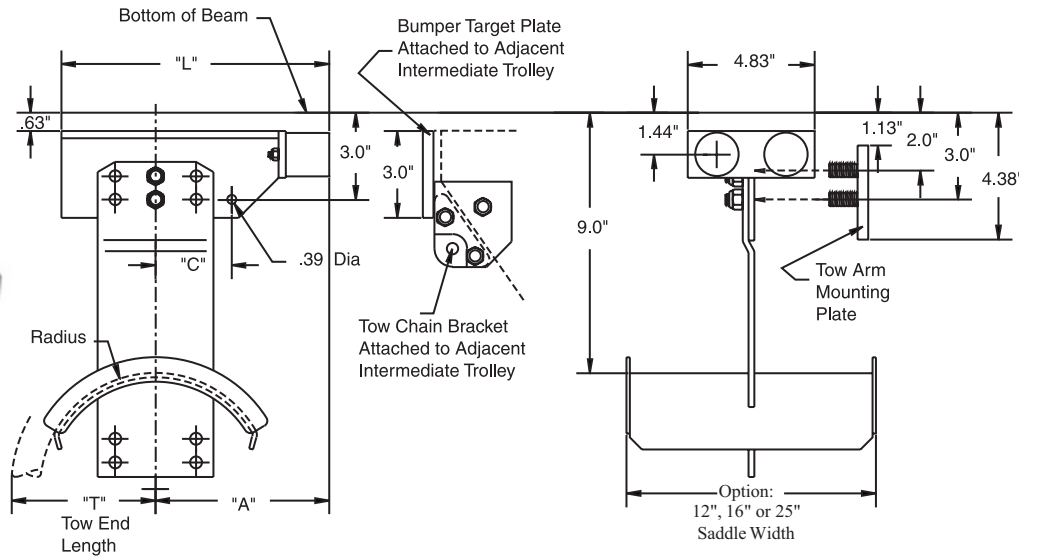

SADDLE											
Type	Radius	Dim "L"	Dim "A"	Dim "T"	Dim "C"	Type	Radius	Dim "L"	Dim "A"	Dim "T"	Dim "C"
A4	4"	9.75"	6.00"	5.00"	3.38"	F6	6"	12.50"	9.25"	8.25"	5.37"
B4	4"	9.75"	6.00"	5.00"	3.38"	A8	8"	14.00"	10.75"	9.75"	7.55"
C4	4"	9.75"	6.00"	5.00"	3.38"	B8	8"	14.00"	10.75"	9.75"	7.55"
D4	4"	10.25"	7.00"	6.00"	3.38"	C8	8"	14.00"	10.75"	9.75"	7.55"
E4	4"	10.25"	7.00"	6.00"	3.38"	D8	8"	15.00"	11.75"	10.75"	7.55"
F4	4"	10.25"	7.00"	6.00"	3.38"	E8	8"	15.00"	11.75"	10.75"	7.55"
A6	6"	11.50"	8.25"	7.25"	5.37"	F8	8"	15.00"	11.75"	10.75"	7.55"
B6	6"	11.50"	8.25"	7.25"	5.37"	AØ	10"	16.50"	13.25"	12.25"	9.83"
C6	6"	11.50"	8.25"	7.25"	5.37"	BØ	10"	16.50"	13.25"	12.25"	9.83"
D6	6"	12.50"	9.25"	8.25"	5.37"	CØ	10"	16.50"	13.25"	12.25"	9.83"
E6	6"	12.50"	9.25"	8.25"	5.37"						

# Mill Duty Tow Trolley

The tow bar passes through the slot of the front end of the tow trolley to propel the trolley. The slot is oversized to provide ample room for the tow bar that eliminates any binding that may occur while system is in motion. It is recommended that anti-lift rollers be used on tow trolleys to prevent trolley from lifting while in motion.

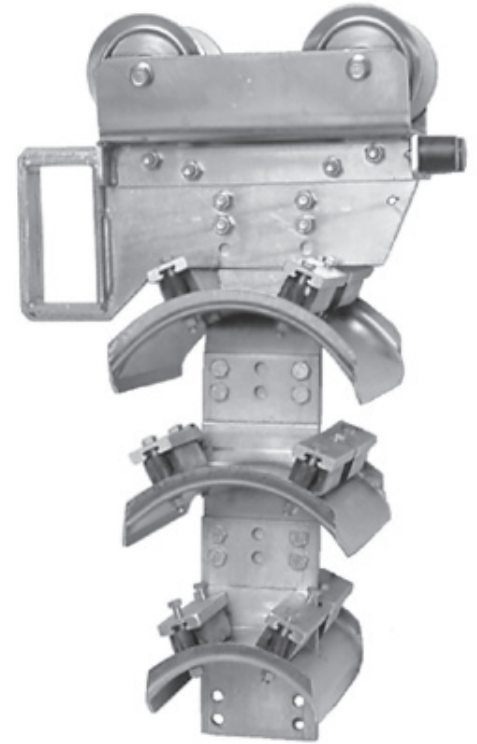
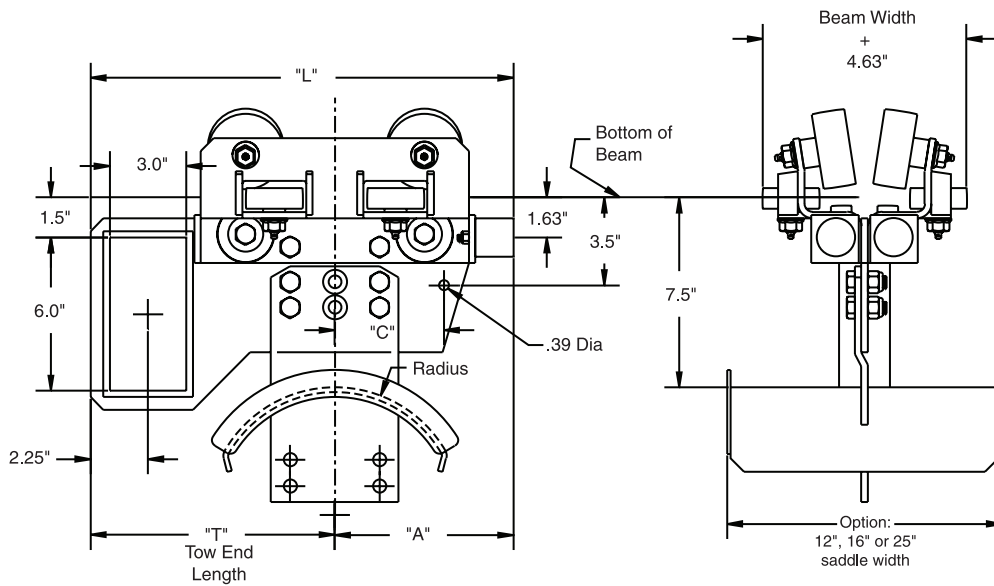

Cable bar clamps are optional

SADDLE											
Type	Radius	Dim "L"	Dim "A"	Dim "T"	Dim "C"	Type	Radius	Dim "L"	Dim "A"	Dim "T"	Dim "C"
A4	4"	14.50"	6.00"	8.60"	3.38"	F6	6"	21.00"	9.25"	11.80"	5.37"
B4	4"	14.50"	6.00"	8.60"	3.38"	A8	8"	24.00"	10.75"	13.30"	7.55"
C4	4"	14.50"	6.00"	8.60"	3.38"	B8	8"	24.00"	10.75"	13.30"	7.55"
D4	4"	16.50"	7.00"	9.60"	3.38"	C8	8"	24.00"	10.75"	13.30"	7.55"
E4	4"	16.50"	7.00"	9.60"	3.38"	D8	8"	26.00"	11.75"	14.30"	7.55"
F4	4"	16.50"	7.00"	9.60"	3.38"	E8	8"	26.00"	11.75"	14.30"	7.55"
A6	6"	19.00"	8.25"	10.80"	5.37"	F8	8"	26.00"	11.75"	14.30"	7.55"
B6	6"	19.00"	8.25"	10.80"	5.37"	AØ	10"	29.00"	13.25"	15.80"	9.83"
C6	6"	19.00"	8.25"	10.80"	5.37"	BØ	10"	29.00"	13.25"	15.80"	9.83"
D6	6"	21.00"	9.25"	11.80"	5.37"	CØ	10"	29.00"	13.25"	15.80"	9.83"
E6	6"	21.00"	9.25"	11.80"	5.37"						

## Mill Duty Intermediate Trolley

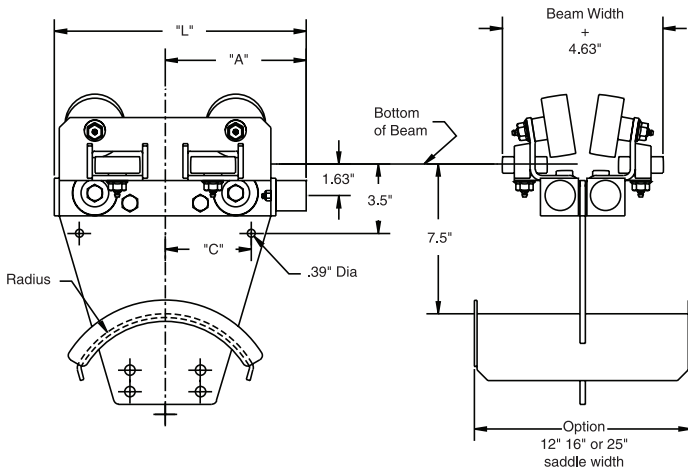

Trolleys are located between the tow trolley and end cable clamp providing cable support as the system expands. Large polyurethane bumpers on the end of each trolley are standard to damper impact between trolleys and end stops.

Cable bar clamps are optional

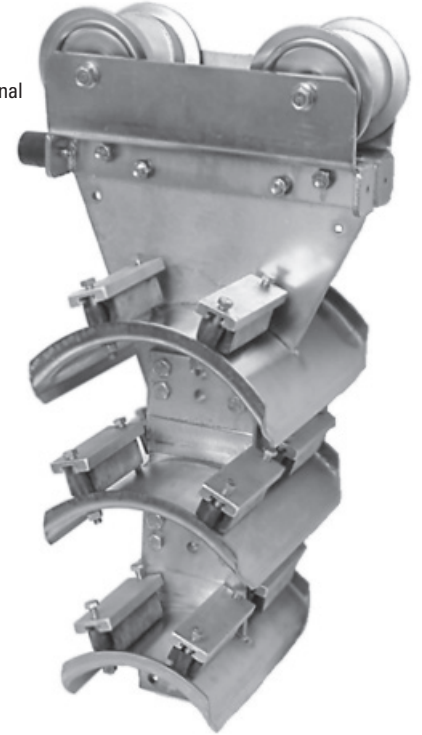

SADDLE									
Type	Radius	Dim "L"	Dim "A"	Dim "C"	Type	Radius	Dim "L"	Dim "A"	Dim "C"
A4	4"	10.50"	6.00"	3.38"	F6	6"	17.00"	9.25"	5.37"
B4	4"	10.50"	6.00"	3.38"	A8	8"	20.00"	10.75"	7.55"
C4	4"	10.50"	6.00"	3.38"	B8	8"	20.00"	10.75"	7.55"
D4	4"	12.50"	7.00"	3.38"	C8	8"	20.00"	10.75"	7.55"
E4	4"	12.50"	7.00"	3.38"	D8	8"	20.00"	11.75"	7.55"
F4	4"	12.50"	7.00"	3.38"	E8	8"	22.00"	11.75"	7.55"
A6	6"	15.00"	8.25"	5.37"	F8	8"	22.00"	11.75"	7.55"
B6	6"	15.00"	8.25"	5.37"	AØ	10"	25.00"	13.25"	9.83"
C6	6"	15.00"	8.25"	5.37"	BØ	10"	25.00"	13.25"	9.83"
D6	6"	17.00"	9.25"	5.37"	CØ	10"	25.00"	13.25"	9.83"
E6	6"	17.00"	9.25"	5.37"					

## Lower Saddle Assemblies

When configuring a component with lower saddles (2<sup>nd</sup> and 3<sup>rd</sup> saddles) the lower saddles must be at least 2" R less than the saddle immediately above it.

Configuration Guidelines		
Main Saddle	2nd Saddle	3rd Saddle
10"R	8"R	6"R
8"R	6"R	4"R
6"R	4"R	N/A

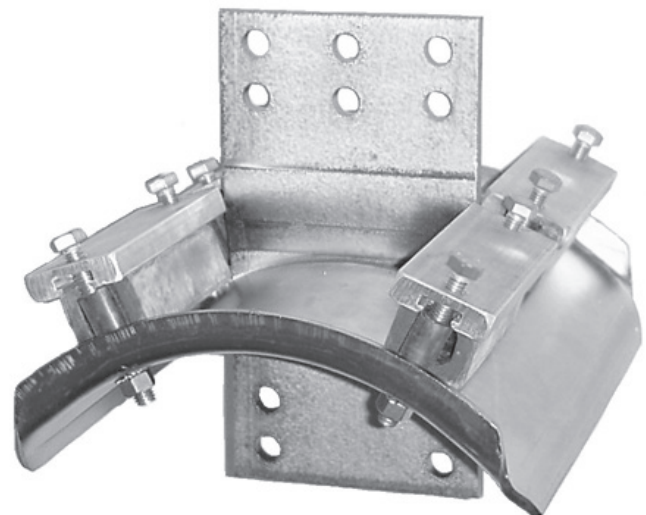

# Electromotive™ Cable

Magnetek furnishes a variety of Electromotive Systems cable specifically designed for festoon applications. The cable is available in a round or flat design, comes standard in a safety yellow color, and most sizes are available for same day shipment.

## Standard Cable Specifications\*:

- Indoor/Outdoor festoon flat cable and round pendant control cable
  - 105° C (221° F) 600 volt A.C., 250 volt D.C.
  - Conductors are annealed copper
  - Each conductor has color coded jacket
  - Jacket rating -40° C (-40° F) to 105° C (221° F).\*\*
  - Resistant to UV, ozone, water, oil and weather
  - 4, 8, or 12 conductor flat cable
  - 8, 12, 16 or 24 conductor round pendant control cable
  - #2 Awg through #16 flat cable
  - #16 Awg round pendant control cable
- \* Special cables are also available—contact the factory for more information.

Festoon Cable		Cable Grips		
Catalog Number	AWG/Conductors	Catalog Number	For Cables	Thread Type
F-2/4	2 Awg-4 Conductors	F-4CG1	(1) F-6/4 or (2)F-12/8	1.50" NPT
F-4/4	4 Awg-4 Conductors	F-4CG2	(1) F-10/4	1.00" NPT
F-6/4	6 Awg-4 Conductors	F-4CG3	(1) F-12/4 or (1) F-14/4	1.00" NPT
F-8/4	8 Awg-4 Conductors	F-4CG4	(1) F-2/4	2.00" NPT
F-10/4	10 Awg-4 Conductors	F-4CG11	(1) F-12/8	1.50" NPT
F-12/4	12 Awg-4 Conductors	F-4CG3	(1) F-12/4 or (1) F-14/4	1.00" NPT
F-14/4	14 Awg-4 Conductors	F-4/8CG2	(1) F-12/4 or (1) F-14/4 & (1) F-14/8 or (1) F-16/8	1.25" NPT
F-12/8	12 Awg-8 Conductors	F-8CG1	(1) F-14/8 or (1) F-16/8	1.25" NPT
F-14/8	14 Awg-8 Conductors	F-8CG2	(2) F-14/8 or (2) F-16/8 or (1) F-8/4	1.25" NPT
F-16/8	16 Awg-8 Conductors	F-12CG1	(1) F-14/12 or (1) F-16/12	2.00" NPT
F-14/12	14 Awg-12 Conductors	F-12CG2	(2) F-14/12 or (2) F-16/12 or (1) F-4/4	2.00" NPT
F-16/12	16 Awg-12 Conductors	F-12CG3	(3) F-14/12 or (3) F-16/12	2.00" NPT

Cable available in specific lengths or in full reels of 500 or 1000 feet.

Cable available in black color—Add Suffix “-B” to the catalog number.

\*\*Magnetek’s flat cable is rated -40°C to 105°C. Round cable is rated -10°C to 90°C. However, they are not recommended for severe flexing or impact at temperatures below -10°C.

For severe flexing applications below -10°C, contact the factory for more information

Pendant		Cable Grips		
Catalog Number	AWG/Conductors	Catalog Number	Cable Diameter	Thread Type
	<b>Strain Relief</b>			
R-16/8SR	16 Awg-8 Conductors	R-CG0	0.236" to 0.472" Inches Cable	.050" NPT
R-16/12SR	16 Awg-12 Conductors	R-CG1	0.394" to 0.709" Inches Cable	0.75" NPT
R-16/16SR	16 Awg-16 Conductors	R-CG2	0.591" to 1.000" Inches Cable	1.00" NPT
R-16/24SR	16 Awg-24 Conductors			
	<b>Non Strain Relief</b>			
R-16/8	16 Awg-8 Conductors			
R-16/12	16 Awg-12 Conductors			
R-16/16	16 Awg-16 Conductors			
R-16/24	16 Awg-24 Conductors			
R-16/30	16 Awg-30 Conductors			

**Special flat and round cables are available. Contact the factory for additional information.**



**MAGNETEK**  
MATERIAL HANDLING

**ELECTROMOTIVE SYSTEMS  
TELEMOTIVE  
ENRANGE  
MONDEL**

www.magnetekmh.com

N49 W13650 Campbell Drive ♦ Menomonee Falls, WI 53051 ♦ p:1.800.288.8178 ♦ f: 1.800.298.3503 ♦ w: www.magnetekmh.com